

Is TimeWise For You?

for Windows

TimeWise

Because Time is Money.

DavidBerman
DEVELOPMENTS

Click mouse button to proceed...



About this slide show

- To advance, press the right arrow.
- To go back one slide, press the left arrow.
- To leave the presentation at any time, press Esc (or Back in your Web browser).

for Windows
TimeWise

Because Time is Money.

Introduction

for Windows
TimeWise

Because Time is Money.

Introduction

What is TimeWise?

- ...it is a time, billing and production management system that runs on a PC under Windows, DOS, or Macintosh.



What is TimeWise?

- ...it is a time, billing and production management system that runs on a PC under Windows, DOS, or Macintosh.
- ...it is a software tool that lets you plan, manage and track jobs from proposal to billing to long-term analysis.

What is TimeWise?

- ...it is a time, billing and production management system that runs on a PC under Windows, DOS, or Macintosh.
- ...it is a software tool that lets you plan, manage and track jobs from proposal to billing to long-term analysis.
- ...it is the solution you have been waiting for!



for Windows
TimeWise

Because Time is Money.

Introduction

TimeWise helps you:

- Track every client and prospect

for Windows
TimeWise

Because Time is Money.

Introduction

TimeWise helps you:

- Track every client and prospect
- Estimate quickly and accurately



for Windows
TimeWise

Because Time is Money.

Introduction

TimeWise helps you:

- Track every client and prospect
- Estimate quickly and accurately
- **Track jobs from start to finish**



for Windows
TimeWise

Because Time is Money.

Introduction

TimeWise helps you:

- Track every client and prospect
- Estimate quickly and accurately
- Track jobs from start to finish
- Track employees, time and expenses



for Windows
TimeWise

Because Time is Money.

Introduction

TimeWise helps you:

- Track every client and prospect
- Estimate quickly and accurately
- Track jobs from start to finish
- Track employees, time and expenses
- **Bill on time *and on budget***



for Windows
TimeWise

Because Time is Money.

Introduction

TimeWise helps you:

- Track every client and prospect
- Estimate quickly and accurately
- Track jobs from start to finish
- Track employees, time and expenses
- Bill on time and on budget
- **Analyse your operation**



for Windows
TimeWise

Because Time is Money.

Introduction

For every job, large or small...

***TimeWise lets you know
where you are!***

for Windows
TimeWise

Because Time is Money.

Introduction

For every job, large or small...

*TimeWise lets you know
where you are!*

Up to the minute!

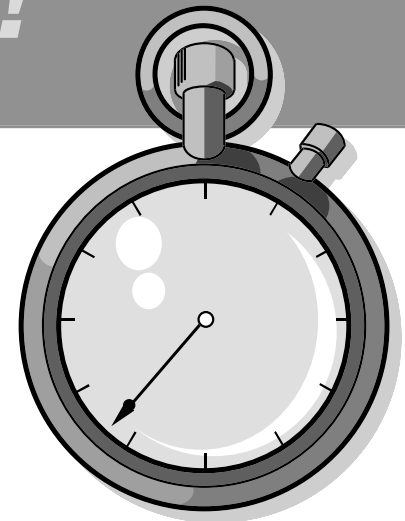



for Windows
TimeWise
Because Time is Money.

Introduction

With TimeWise:

- It's easy to install, easy to use and easy to get help if you need it!



for Windows
TimeWise
Because Time is Money.

Introduction

With TimeWise:

- It's easy to install, easy to use and easy to get help if you need it!
- You get 24 hour, 7 day telephone support



for Windows
TimeWise

Because Time is Money.

Introduction

With TimeWise:

- It's easy to install, easy to use and easy to get help if you need it!
- You get 24 hour, 7 day telephone support
- Training is available



for Windows
TimeWise

Because Time is Money.

Introduction

With TimeWise:

- Its easy to install, easy to use and easy to get help if you need it!
- You can get 24 hour, 7 day telephone support
- Training is available
- You can buy the program “off the shelf”, or else have it customized to further meet *your* needs



How Does TimeWise Work?

for Windows
TimeWise

Because Time is Money.

How Does TimeWise Work?

- **TimeWise works by carrying information through every part of your work process**

for Windows
TimeWise

Because Time is Money.

How Does TimeWise Work?

TimeWise works by carrying information through every part of your work process
from the initial estimate...

The Indelible Inc.

77 Wellesley Rd, Port Perry, OH, 21103

Tel: (216) 565-8933 Fax: (216) 566-1099

Estimate Date: 12th June 1996

Ready Date: 17th August 1996

Job Estimate

Client Name: John Smith & Company

Client Address: 123 Main Street

Mapleville, OH 21099

Contact Name: John Smith

Tel: (303) 123-4567

Description:	Subtotal
Design to client specs 4hrs @ \$50/hr	\$200.00
Print 5000 8.5 x 11 b/w @ 0.06/unit	\$300.00

for Windows TimeWise

Because Time is Money.

How Does TimeWise Work?

- TimeWise works by carrying information through every part of your work process
- to tracking each part of the job and the time it takes...

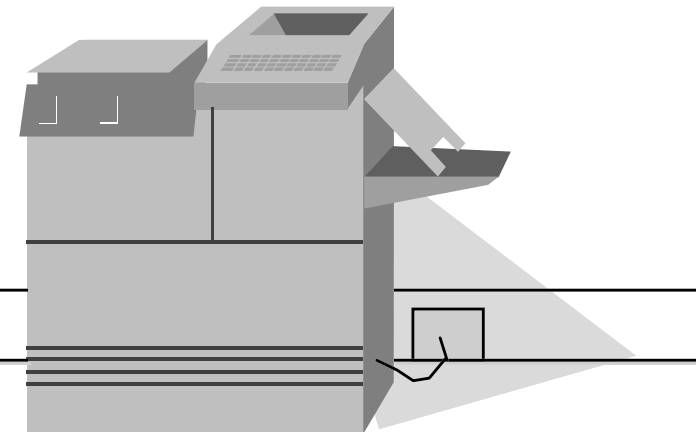
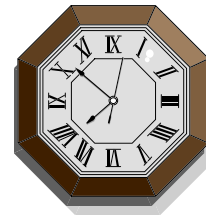

TimeWise

for Windows

Because Time is Money.

How Does TimeWise Work?

- TimeWise works by carrying information through every part of your work process
- **tracking vendors, expenses and deliveries made...**

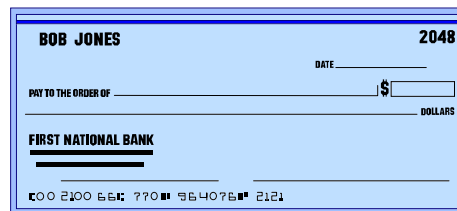
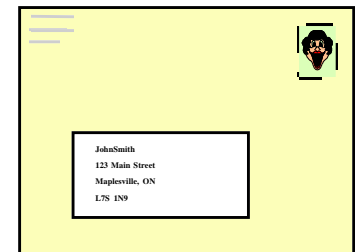
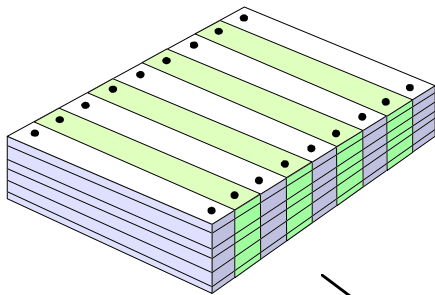

for Windows
TimeWise

Because Time is Money.

How Does TimeWise Work?

- TimeWise works by carrying information through every part of your work process
- **right up to billing the job...**

The Indelible Inc.

77 Wellesley Rd, Port Perry, OH, 21103

Tel: (216) 565-8933 Fax: (216) 566-1099

Invoice Date: 18th December 1996

Invoice Number: 1882/96

Invoice

Client Name: John Smith & Company

Client Address: 123 Main Street

Maples,ville OH 21099

Contact Name: John Smith

Tel: (303) 123-4567

Description:

Design to client specs 4hrs @ \$50/hr

Print 5000 8.5 x 11 b/w @ 0.06/unit

Subtotal

\$200.00

\$300.00



for Windows
TimeWise

Because Time is Money.

How Does TimeWise Work?

- **Because each step of the job is tracked...**



for Windows
TimeWise

Because Time is Money.

How Does TimeWise Work?

- Because each step of the job is tracked...
- **you can use this information to analyse your activity and to generate one of TimeWise's many built-in reports**

- You can also export information to your spreadsheet, word processor or database software.

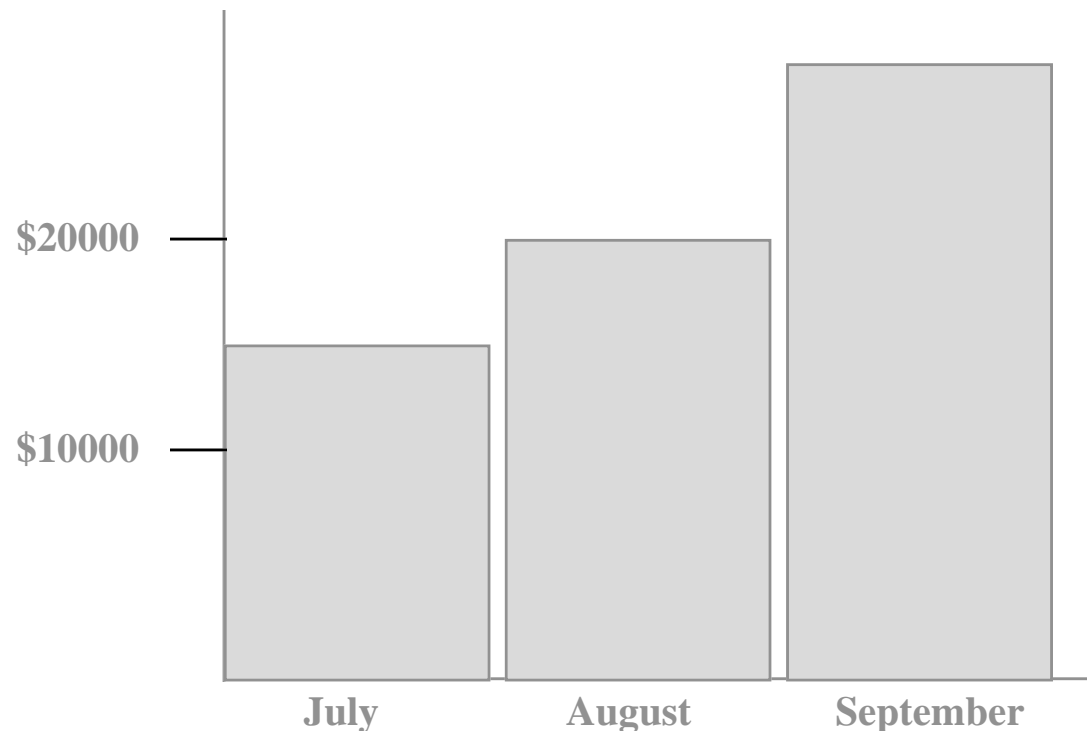

Indelible Inc.

Sales Report
(95Q3).

for Windows
TimeWise
Because Time is Money.

Client Information



Client Information

- With TimeWise, you will have all the information you need about a client in one easy-to-locate place.

The screenshot shows a 'New Client' form with the following fields and options:

- Name:** Sherlock Homes
- Client ID:** SHERLO
- Mailing Address:** 221b Baker Street, London, Ontario
- Postal Code:** L1M 1Y0
- Client Group:** K) Large Business
- Status:** Active, Prospect
- Main Contact:** Dr Watson
- Title:** Chief Assistant
- Phone:** (905) 227-7070 /
- Home Phone:** () -
- Fax:** (905) 227-7071
- Alternate Fax/Modem:** (905) -
- Cellular Phone:** (905) -

Navigation buttons at the bottom include: Contacts, Shipping, Financial, Advanced, Notes, OK, and Cancel.



Client Information

- With TimeWise, you will have all the information you need about a client in one easy-to-locate place.

A screenshot of the 'New Client' form in the TimeWise software. The form is titled 'New Client' and contains several input fields and a status selection area. The 'Name' field is filled with 'Sherlock Homes' and the 'Client ID' field is filled with 'SHERLO'. The 'Mailing Address' section includes '221b Baker Street', 'London', and 'Ontario', with a 'Postal Code' field filled with 'L1M 1Y0'. The 'Client Group' is set to 'K) Large Business'. The 'Status' section has two radio buttons: 'Active' (unselected) and 'Prospect' (selected). The 'Main Contact' section includes a name field filled with 'Dr Watson', a title field filled with 'Chief Assistant', and several phone number fields: 'Phone: (905) 227-7070 /', 'Home Phone: () -', 'Fax: (905) 227-7071', 'Alternate Fax/Modem: (905) -', and 'Cellular Phone: (905) -'. At the bottom of the form, there are several buttons: 'Contacts', 'Shipping', 'Financial', 'Advanced', 'Notes', 'OK', and 'Cancel'.

- Everyone in your organization can have the client information you want them to have - no need for separate client lists!



Client Information

- With TimeWise, you can have all the information you need about a client in one easy-to-locate place.

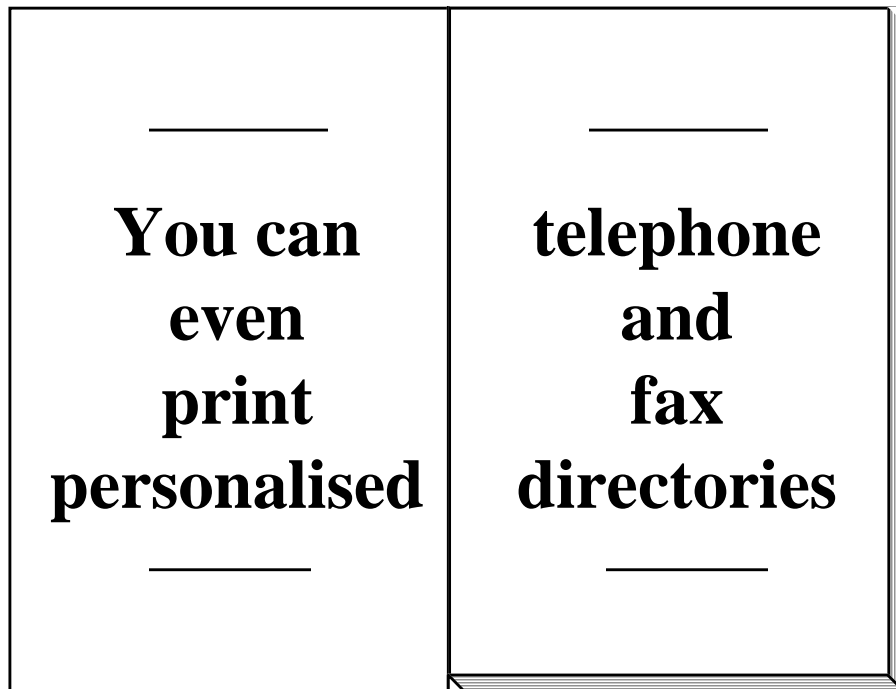

- Everyone in your organization can have the client information you want them to have - no need for separate client lists!

for Windows
TimeWise

Because Time is Money.

Client Information

- **TimeWise can handle very complex client profiles:**

Client Information

- TimeWise can handle very complex client profiles:
- **Full address and split shipping address.**

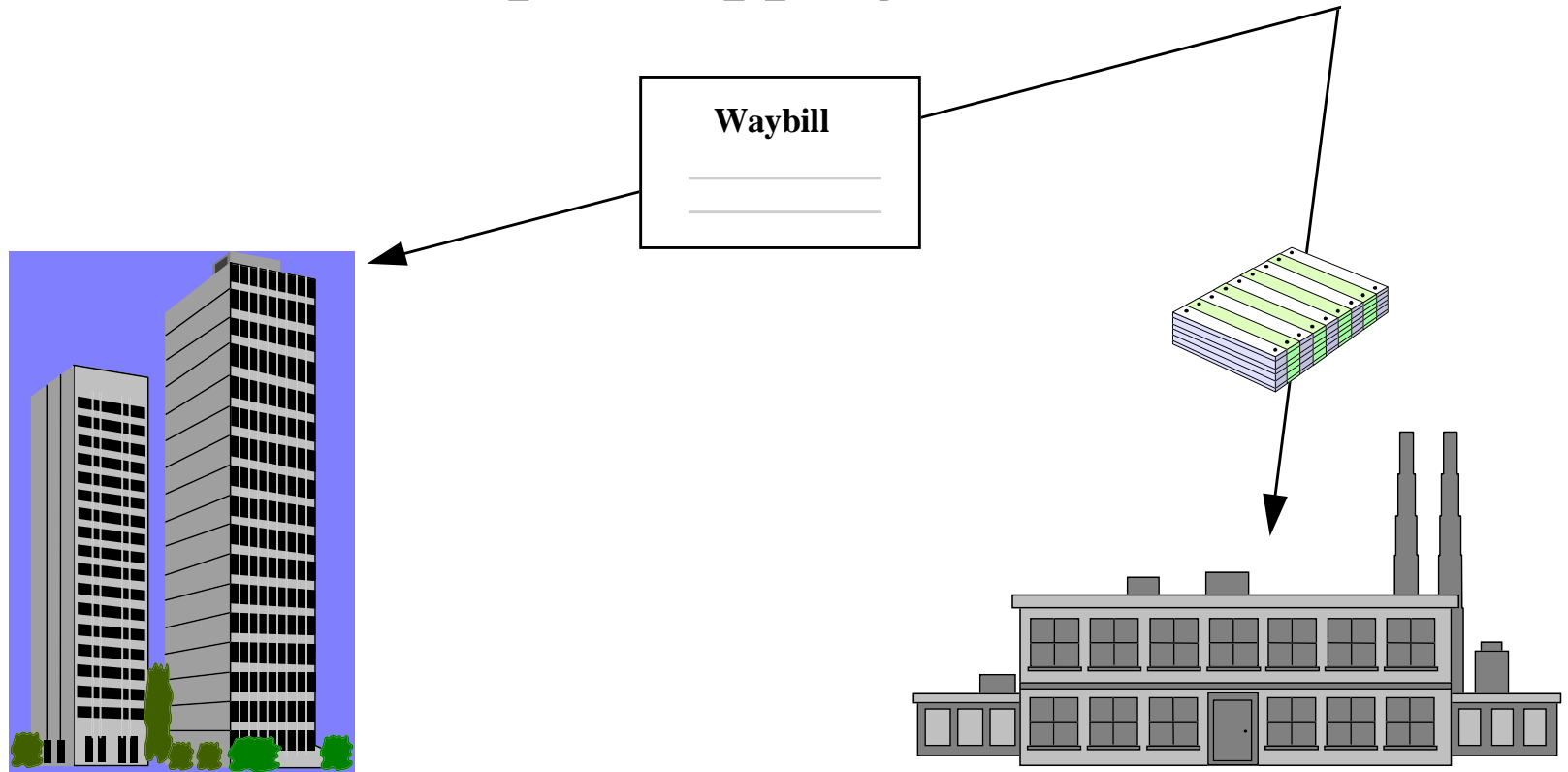

Client Information

- TimeWise can handle very complex client profiles:
- Full address and separate shipping address.
- **Up to 10 different contact names and multiple numbers per client**

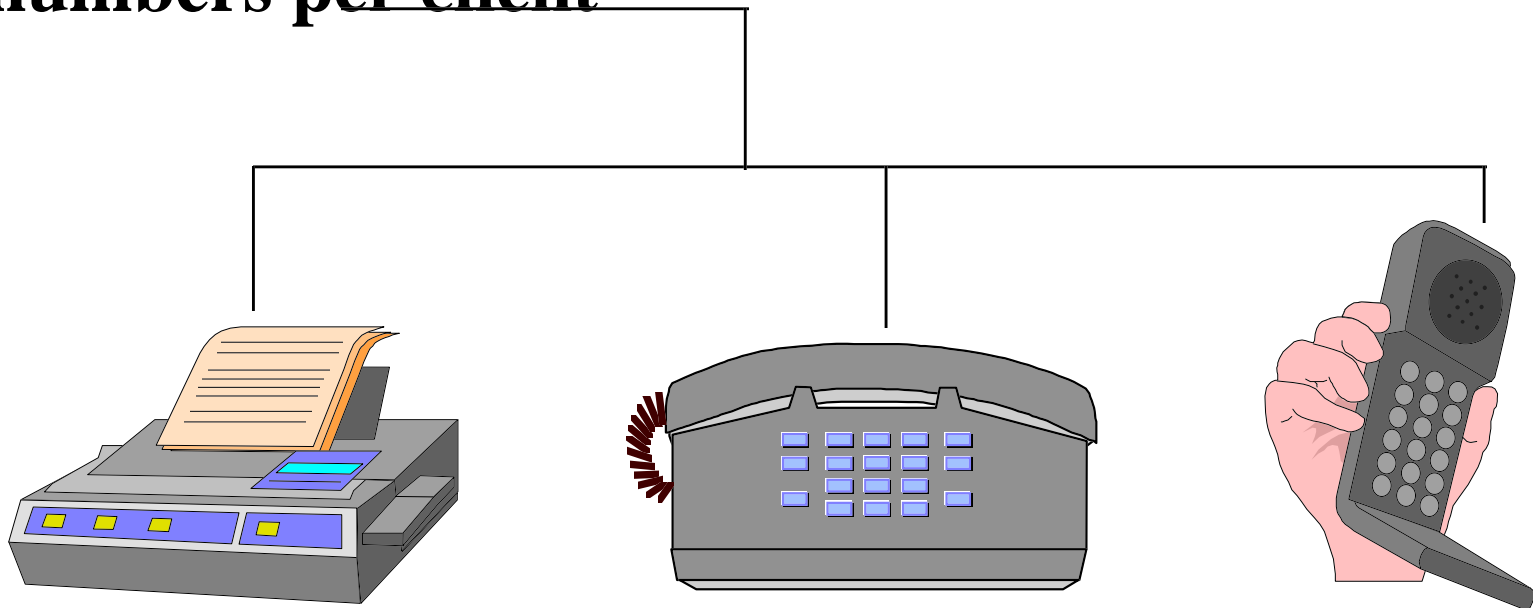



Client Information

- TimeWise can handle very complex client profiles:
- Full address and separate shipping address
- Up to 10 different contact names and multiple contact numbers
- **Clients' financial information such as credit limits and discounts**

for Windows
TimeWise

Because Time is Money.

Client Information

- TimeWise can handle very complex client profiles:
- Full address and separate shipping address
- Up to 10 different contact names and multiple contact numbers
- Clients' financial information such as credit limit and discounts
- **Classify your clients by type of business or whether they are active clients or prospects**



for Windows
TimeWise

Because Time is Money.

Client Information

- TimeWise can handle very complex client profiles:
- Full address and separate shipping address
- Up to 10 different contact names and multiple contact numbers
- Clients' financial information such as credit limit and discounts
- Classify your clients by type of business or whether they are active clients or prospects
- **Specify language preference, invoice format, client birthdays and unlimited random notes**

for Windows
TimeWise

Because Time is Money.

Client Information

What does this allow **you** to do?



Client Information

- You can access client information quickly and easily



Client Information

- You can access client information quickly and easily
- Your sales team can use TimeWise to track prospects...reps can track their own leads

for Windows
TimeWise

Because Time is Money.

Client Information

- You can access client information quickly and easily
- Your sales team can use TimeWise to track prospects...reps can track their own leads
- **Easily change a prospect into a client: no additional information required!**



Client Information

- You can access client information quickly and easily
- Your sales team can use TimeWise to track prospects...reps can track their own leads
- Easily change a prospect into a client: no additional information required!
- **Create mailing labels or mail merges using your favorite word processor**



Client Information

- You can access client information quickly and easily
- Your sales team can use TimeWise to track prospects...reps can track their own leads
- Easily change a prospect into a client: no additional information required!
- Create mail labels or mail merges using your favorite word processor
- **View spending habits and profile reports**



Client Information

- TimeWise can track all your vendor information as well.



Client Information

- TimeWise can track all of your vendor information as well.
- According to the job needs, TimeWise will suggest who supplies what and for how much.



Client Information

- TimeWise can contain all of your vendor information as well.
- According to the job needs, TimeWise will suggest who supplies what and for how much.
- TimeWise will help you draft purchase orders, and can even issue a check request as you charge expenses!



Job Estimating

for Windows
TimeWise

Because Time is Money.

Job Estimating

- You only have to estimate the jobs you want to estimate

for Windows
TimeWise

Because Time is Money.

Job Estimating

- You only have to estimate the jobs you want to estimate - at the level of detail you choose



Job Estimating

- You only have to estimate the jobs you want to estimate - at the level of detail you choose
- With TimeWise, consider an estimate as simply a job waiting to happen

Job Estimating

- You only have to estimate the jobs you want to estimate - at the level of detail you choose
- With TimeWise, consider an estimate as simply a job waiting to happen
- Based on past history, quickly charge each component that you expect will be required

Job Estimating

- You only have to estimate the jobs you want to estimate - at the level of detail you choose
- With TimeWise, consider an estimate as simply a job waiting to happen
- Based on past history, quickly charge each component that you expect will be required
- A “snapshot” analysis summary lets you know if charges have not been entered or are lower than the minimum charge for the task

- You can also print a proposal or quote...

Proposal

Total Quote (before tax):

Total Quote: (from estimate ticket) \$603.00

Sales Tax:

GST:	<input type="text" value="\$42.21"/>	(at 7.000%)	<input checked="" type="checkbox"/> Automatically Calculate
PST:	<input type="text" value="\$48.24"/>	(at 8.000%)	<input checked="" type="checkbox"/> Automatically Calculate

Charge Total: \$ 603.00 +GST \$42.21+PST \$48.24=\$693.45

Draft Detail:

- No Detail The body is left blank for you to fill in as you see fit.
- Simple Detail Time charges are summarized by department. All items charges appear.
- Medium Detail Time charges are summarized by category. All item charges appear.
- Complete Detail All time charges appear. All item charges appear in detail.
- Edit Previous Version Rather than drafting a new version, you edit the previous version.
- No Printed Version No draft is created. Totals are recorded and you return to other work.

Proposal Date: Wednesday, June 12, 1996

Payment Due Date: (net 30 days) Friday, July 12, 1996

- TimeWise lets you construct a brand new estimate from scratch...

New Job

New Estimate

Clone from job or estimate number

Change An Estimate Into A Job

- or you can “clone” the information from a previous estimate or job.

New Job

New Estimate

← Clone from job or estimate number

9106 FEDE

Change An Estimate Into A Job

for Windows
TimeWise

Because Time is Money.

Job Estimating

- or you can “clone” the information from a previous estimate or job.

This flexibility allows you to quickly process clients with repeat or similar orders.

Job Estimating

- TimeWise also allows you great flexibility in estimating charges.

Time Charge

Job # (or Client) Client: Sherlock Homes (The Builde Estimated
 Department: Task Category:

<input type="radio"/> Miscellaneous	A) Client Meeting/Consultation	Sort 01	\$ 75.00/hr	+
<input checked="" type="radio"/> Administration	B) Presentation to Client	Sort 05	\$ 75.00/hr	
<input type="radio"/> Reproduction	C) Project Coordination	Sort 10	\$ 40.00/hr	
<input type="radio"/> Design	D) Clerical	Sort 29	\$ 25.00/hr	
<input type="radio"/> Pre-press	E) Administration	Sort 30	\$ 60.00/hr	
<input type="radio"/> Camera Ready				
<input type="radio"/> Print Commissi				

Description
 How long 15-minute slices x \$ 75.00/hour =\$ 56.25
 Employee Betty Dymontio
 Rush Level
 Date Friday, July 5
 Alteration (Yes, No or Round 1 to 9) =\$ time charge

Job Estimating

- TimeWise allows you great flexibility in estimating charges.
- You can enter time charges, and decide what interval you wish to use...day, hour, quarter hour, minute: any interval that is convenient.

Description	F/C flyer - get specs		
How long	3.00	15-minute slices x \$ 75.00/hour	= \$ 56.25
Employee	BD	Betty Dymontio	
Rush Level	(Space 100%, Rush)		
Date	07/05/96	Friday, July 5	
Alteration	N	(Yes, No or Round 1 to 9)	= \$ 56.25 time charge

- TimeWise allows you great flexibility in estimating charges.
- Alternatively, some departments might need to charge per unit. (By the page, for example).

Departments Involved:

<input checked="" type="checkbox"/> Admin	<input checked="" type="checkbox"/> Unit Pricing
<input checked="" type="checkbox"/> Reprod	<input type="checkbox"/> Unit Pricing
<input type="checkbox"/> Design	
<input checked="" type="checkbox"/> PrePrs	

Units:
15,000

Job Estimating

- TimeWise allows you great flexibility in estimating charges.
- You can also charge by item. TimeWise tracks up to 1200 expense categories *in each department!*

Estimated Item Charge			
Printing			
Job # (or Client)	1012	for Sherlock Homes (The Bu	<input checked="" type="checkbox"/> Estimated
Description	F/C on A3 fold		
Our Cost	1,385.00	(0 if not yet known)	Markup 25.00%
Employee	BS	Bart Simpson	
Rush Level	(Space 100%, Rush 130%)		
Date	07/03/96	Wednesday, July 3	<input checked="" type="checkbox"/> Bill Client
Vendor			
1385.00 + 25.00%		= \$ 1,731.25	

for Windows
TimeWise

Because Time is Money.

Job Estimating

- TimeWise allows you great flexibility in estimating charges.
- You can also charge by item. TimeWise tracks up to 1200 expense categories *in each department!*
- Item charges can be variable- or fixed-price and include cost/sell prices or markup percentage and two levels of rush service.

for Windows
TimeWise

Because Time is Money.

Job Estimating

- TimeWise allows you great flexibility in estimating charges.
- You can also charge by item. TimeWise tracks up to 1200 expense categories *in each department!*
- You can also build discount curves with up to eight levels of volume pricing in each category.

for Windows
TimeWise

Because Time is Money.

Job Estimating

- TimeWise allows you great flexibility in estimating charges.
- Individual time and item can also be consolidated into Charge Groups.

for Windows
TimeWise

Because Time is Money.

Job Estimating

- TimeWise allows you great flexibility in estimating charges.
- Individual time and item charges can also be consolidated into Charge Groups.
- Each charge group includes as many charges as you wish in over 15 charge categories. Use them to speed data entry and reduce forgotten charges.

for Windows
TimeWise

Because Time is Money.

Job Estimating

- You can easily edit and delete the charges that you estimate.

- You can easily edit and delete the charges that you estimate.
- This is especially useful if you “clone” details from an already existing job or estimate...you can quickly change details that will differ in the new estimate.

for Windows
TimeWise

Because Time is Money.

Job Estimating

- TimeWise lets you design up to 10 proposal styles to suit individual clients.

for Windows
TimeWise

Because Time is Money.

Job Estimating

- TimeWise lets you design up to 10 proposal styles to suit individual clients.
- You can also choose from four levels of detail for each proposal.

for Windows
TimeWise

Because Time is Money.

Job Estimating

- TimeWise lets you design up to 10 proposal styles to suit individual clients.
- You can also choose from four levels of detail for each proposal.
- You can print the proposal or fax it using any fax software.

for Windows
TimeWise

Because Time is Money.

Job Estimating

- TimeWise lets you design up to 10 proposal styles to suit individual clients.
- You can also choose from four levels of detail for each proposal.
- You can print the proposal or fax it using any fax software.

This allows you to tailor an estimate to exactly meet your client's needs.

- With TimeWise you can plan up to 15 “Milestones” for each job

Current Phase		Start Date		at	
<input checked="" type="radio"/>	A: Consultation	06/05/97			09:45
<input type="radio"/>	B: Design	06/12/97			
<input type="radio"/>	C: Approval	06/29/97			
<input type="radio"/>	D: Production	07/04/97			
<input type="radio"/>	E: Reproduction	07/06/97			
<input type="radio"/>	F: Distribution	07/09/97			

- With TimeWise you can plan up to 15 “Milestones” for each job

Milestones		
Current Phase	Start Date	
<input checked="" type="radio"/> A: Consultation	06/05/97	at 09:45
<input type="radio"/> B: Design	06/12/97	
<input type="radio"/> C: Approval	06/29/97	
<input type="radio"/> D: Production	07/04/97	
<input type="radio"/> E: Reproduction	07/06/97	
<input type="radio"/> F: Distribution	07/09/97	

Using Milestones allows you to plan how long a job will take and, as it progresses, allows you to assess whether or not it will be completed on target.

for Windows
TimeWise

Because Time is Money.

Job Estimating

- With TimeWise you can also print a report of outstanding estimates

for Windows
TimeWise

Because Time is Money.

Job Estimating

- With TimeWise you can also print a report of outstanding or declined estimates, filtered by sales rep
- This makes an excellent agenda for sales meetings

for Windows
TimeWise

Because Time is Money.

Job Estimating

- With TimeWise you can also print a report of outstanding or declined estimates, filtered by sales rep
- ...making an excellent agenda for sales meetings

TimeWise helps you maximize sales volume and report orders!



From Estimate to Job

- Change an estimate into an active job with a simple click of a button

New Job

New Estimate

Clone from job or estimate number

Change An Estimate Into A Job

for Windows
TimeWise

Because Time is Money.

From Estimate to Job

- Changing an estimate into an active job is done by the simple click of a button
- No need to retype any information: everything you need is already there

for Windows
TimeWise

Because Time is Money.

From Estimate to Job

- Changing an estimate into an active job is done by the simple click of a button
- No need to retype any information: everything you need is already there
- While changing the estimate into a job, TimeWise makes it easy for you to amend, add or remove job information



for Windows
TimeWise

Because Time is Money.

From Estimate to Job

- Changing an estimate into an active job is done by the simple click of a button
- No need to retype any information: everything you need is already there
- While changing the estimate into a job, TimeWise makes it easy for you to amend, add or remove job information
- **TimeWise retains the estimate for later comparisons with the actual job charges**



Job Tracking

for Windows
TimeWise

Because Time is Money.

Job Tracking

- Remember that you can create a job without an estimate

- Remember that you can create a job without an estimate
- When you change an estimate into a job or when you create a new job, you can print **job tickets** for all the departments that require them

Job Ticket

Est # 1012

Title: Baskerville Estates Flyer

Client: SHERLO

Start Date: 07/03/96 at 08:47 am

Next Due: Phase **A** 07/10/96 Orientation

Ultimate Due Date: 08/05/96 at

Client: Sherlock Homes (The Builder)

Contact: Dr Watson

Phone: (219) 767-8799 / 21

Home Phone: (219) 766-1904

Delivery Instructions: Call when ready

Rush Level: Normal Rush

Job Type: Print Advertising

Project: BE Flyer

PO Number: 20998 (or "pending")

Filename:

CST SST SST# 2778-09938

Departments Involved:

Admin

Reprod

Design

PrePrs

Unit Pricing

Unit Pricing

Units:

0

CRA

PrComm

Unit Pricing

Representative: RK (Roy Ketchup)

Milestones

Ship Address

Notes

Quotation

OK

Cancel

Job Tracking

- As the job progresses, you can add new charges or edit existing ones.

Edit/Delete Actual Charge					
Date	By	Category	Description	Hours	Charge
Jul 3 /96	AD	Client Meeting/		0.50	37.50
Jul 3 /96	AD	Project Coordin		0.75	30.00
Jul 3 /96	AD	Clerical		1.00	25.00
Jul 3 /96	AD	Print Specs		0.50	37.50
Jul 3 /96	AD	Checking Blues/		0.50	37.50
Jul 5 /96	BS	Design/Typograp	F/C Flyer	1.75	131.25
Jul 3 /96	DB	Internal Meetin		0.75	0.00

Type of Charge:
 Time Charges
 Item Charges

Actual or Estimated:
 Display Actual Charges
 Display Estimated Charges

Total: 298.75

for Windows
TimeWise

Because Time is Money.

Job Tracking

“Do I need to enter everything into TimeWise as it happens?”

“Do I need to enter everything into TimeWise as it happens?”

- It is up to you to decide how much detail you wish to enter.

“Do I need to enter everything into TimeWise as it happens?”

- It is up to you to decide how much detail you wish to enter.
- TimeWise is designed to automate tracking your work process, while flexible enough to respond to your specific needs and to be as detailed as you choose to make it.

“Do I need to enter everything into TimeWise as it happens?”

- You might prefer to keep some parts of a job paper-based. You can enter events after-the-fact or in summary form, or else use TimeWise’s built-in timers to help track events as they occur.

“Do I need to enter everything into TimeWise as it happens?”

- However and whenever you choose to do it, you need only ensure that you enter the data TimeWise requires to give you the results *you* desire

“Do I need to enter everything into TimeWise as it happens?”

- However and whenever you choose to do it, you need only ensure that you enter the data TimeWise requires to give you the results *you* desire
- Here is an example of how flexible TimeWise can be...

for Windows
TimeWise

Because Time is Money.

Job Tracking

- You can have employees enter their own detailed time-sheets...

for Windows
TimeWise

Because Time is Money.

Job Tracking

- You can have employees enter their own detailed time-sheets...
- ...or you can have staff enter only time charges on individual jobs...

for Windows
TimeWise

Because Time is Money.

Job Tracking

- You can have employees enter their own detailed automated time-sheets...
- ...or you can have your employees enter only time charges on individual jobs...
- ...or you can collect paper timesheets and have one person enter the details...



for Windows
TimeWise

Because Time is Money.

Job Tracking

- You can have employees enter their own detailed automated time-sheets...
- ...or you can have your employees enter only time charges on individual jobs...
- ...or you can collect paper timesheets and have one person enter the details...
- ...or you can manually total all the time charges for a job and enter the total figure into TimeWise

for Windows
TimeWise

Because Time is Money.

Job Tracking

With TimeWise, you control the process - it doesn't control you!



Staff

for Windows
TimeWise

Because Time is Money.

Staff

- Every member of your organisation can benefit from using TimeWise...

for Windows
TimeWise

Because Time is Money.

Staff

- Every member of your organisation can benefit from using TimeWise...
- ...the president who needs long-term client profitability analysis...

for Windows
TimeWise

Because Time is Money.

Staff

- Every member of your organisation can benefit from using TimeWise...

- ...the accountant needing a report of work in progress...

for Windows
TimeWise

Because Time is Money.

Staff

- Every member of your organisation can benefit from using TimeWise...

- ...the production manager who needs a jobs-in-progress report...

for Windows
TimeWise

Because Time is Money.

Staff

- Every member of your organisation can benefit from using TimeWise...

- ...the shipping clerk who needs to know which jobs are to be dispatched that day

for Windows
TimeWise

Because Time is Money.

Staff

- Of course, you might not want everybody on your network to be able to access all your records.

for Windows
TimeWise

Because Time is Money.

Staff

- Of course, you might not want everybody on your network to be able to access all your records.
- TimeWise contains an extensive security system which allows you to carefully limit what each individual can see and do.

for Windows
TimeWise

Because Time is Money.

Staff

- TimeWise allows you to keep complete staff information, whether those staff be full-time, part-time or freelance.

for Windows
TimeWise

Because Time is Money.

Staff

- TimeWise allows you to keep complete staff information, whether those staff be full-time, part-time or freelance.
- TimeWise lets you rate each employee for efficiency on up to 250 tasks.

for Windows
TimeWise

Because Time is Money.

Staff

- TimeWise allows you to keep complete staff information, whether those staff be full- or part-time or even freelancers.
- TimeWise lets you rate each employee for efficiency on up to 250 tasks.
- This allows you to adjust the rates for new employees or employees who are especially efficient.

for Windows
TimeWise

Because Time is Money.

Staff

- TimeWise allows you to keep complete staff information, whether those staff be full-time, part-time, or freelance.
- TimeWise will also provide timely payroll information and print the reports you need: by employee, by department or for you entire organisation.



Billing

for Windows
TimeWise

Because Time is Money.

Billing

- Because TimeWise contains all the information about a job, it easily takes care of the preparation of invoices

for Windows
TimeWise

Because Time is Money.

Billing

- Because TimeWise contains all the information about a job, it easily takes care of the preparation of invoices
- TimeWise will print invoices or credit notes at the touch of a button

for Windows
TimeWise

Because Time is Money.

Billing

- Because TimeWise contains all the information about a job, it easily takes care of the preparation of bills
- TimeWise will print invoices or credit notes at the touch of a button
- You can bill by the hour, by the unit or a combination

for Windows
TimeWise

Because Time is Money.

Billing

- Because TimeWise contains all the information about a job, it easily takes care of the preparation of bills
- TimeWise will print invoices or credit notes at the touch of a button
- You can bill by the hour, by the unit or a combination
- **TimeWise automatically calculates all taxes payable**

for Windows
TimeWise

Because Time is Money.

Billing

- TimeWise lets you allocate sales revenue to each department from the job information already on hand

for Windows
TimeWise

Because Time is Money.

Billing

- TimeWise lets you allocate sales revenue to each department from the job information already on hand
- You can edit this allocation, re-allocating revenue as you desire

for Windows
TimeWise

Because Time is Money.

Billing

- TimeWise lets you allocate sales revenue to each department from the job information already on hand
- You can edit this allocation, re-allocating revenue as you desire
- You can automatically transfer invoice details to common accounting software packages

for Windows
TimeWise

Because Time is Money.

Billing

- TimeWise lets you allocate sales revenue to each department from the job information already on hand
- You can edit this allocation and re-allocate revenue in any desired way
- You can automatically transfer invoice details to common accounting software packages
- An electronic copy of the invoice is created for further improvement in your word processor or for viewing any time

for Windows
TimeWise

Because Time is Money.

Billing

- Use the Billing Summary Report to review and analyze all jobs billed during a period of your choice.

Billing

- Use the Billing Summary Report to review and analyze all jobs billed during a period of your choice. This report is especially useful in calculating tax collected that has to be periodically remitted.

- A Billing Summary Report lets you review jobs billed over a period extending back as far as nine years. This report is especially useful in calculating tax collected that has to be periodically remitted.
- You can also examine a report analyzing all jobs billed to a particular client or range of clients.



Reports

for Windows
TimeWise

Because Time is Money.

Reports

- TimeWise's built-in reports keep you on top of of income and expenditures to assess how your organisation is performing.

The many reports you can run include:

Payroll

Employee
Activity

The many reports you can run include:

■ Payroll

■ Employee
Activity

■ **Work in Progress**

— — — — —
— — — — —
— —

The many reports you can run include:

■ Payroll

■ Employee
Activity

■ Work in Progress

■ **Sales Commission**

Reports

The many reports you can run include:

■ Payroll

■ Employee
Activity

■ Work in Progress

■ Sales Commission

■ Jobs Completed

Reports

The many reports you can run include:

■ Payroll

■ Employee
Activity

■ Work in Progress

■ Sales Commission

■ Jobs Completed

■ **Client Sales**

Reports

The many reports you can run include:

■ Payroll

■ Employee
Activity

■ Work in Progress

■ Sales Commission

■ Jobs Completed

■ Client Sales

■ **Billing Summary**

Reports

The many reports you can run include:

■ Payroll

■ Employee
Activity

■ Work in Progress

■ Sales Commission

■ Jobs Completed

■ Client Sales

■ Billing Summary

■ **Client Experience**

Reports

The many reports you can run include:

■ Payroll

■ Employee
Activity

■ Work in Progress

■ Sales Commission

■ Jobs Completed

■ Client Sales

■ Billing Summary

■ Client Experience

■ Quiet Client

for Windows
TimeWise

Because Time is Money.

Reports

- You can also use the information TimeWise contains to design your own custom reports which exactly suit your needs.

for Windows
TimeWise

Because Time is Money.

Reports

- You can also use the information TimeWise contains to design your own custom reports which exactly suit your needs.
- Or you can export information into any database, spreadsheet or report writing software.



TimeWise
has been helping
organizations like
yours since 1987.



**To find out more about
how TimeWise can
help you...**



Contact:

Sales: 1-800-665-1809

Fax: (613) 728-2867

E-mail: info@timewise.net



You can also write to us at:

David Berman Developments Inc.

283 Ferndale Avenue

Ottawa, Ontario, Canada K1Z 6P9

or visit our Web site at:

<http://www.timewise.net>

Thank you for looking over

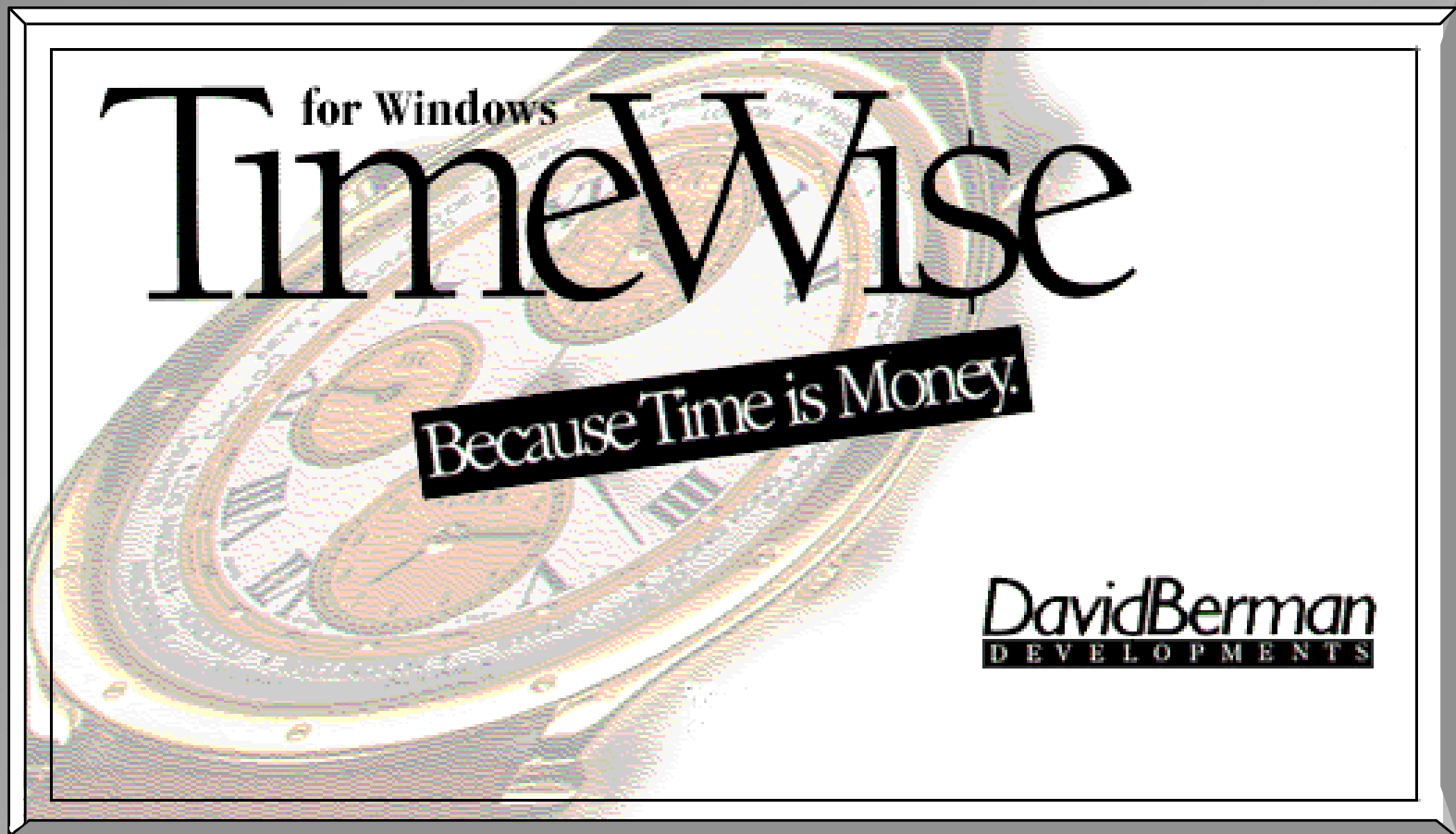
An advertisement for 'TimeWise' software. The background is a close-up of a gold watch face with Roman numerals and several gold coins. The text 'TimeWise' is written in a large, black, serif font, with 'for Windows' in a smaller font above the 'W'. A black banner with white text reads 'Because Time is Money.'. In the bottom right corner, the logo for 'DavidBerman DEVELOPMENTS' is displayed, with 'DavidBerman' in a serif font and 'DEVELOPMENTS' in a smaller, all-caps sans-serif font below it.

TimeWise for Windows

Because Time is Money.

DavidBerman
DEVELOPMENTS

**Contact us today...because time is
money!**